

# Case Packer Machine Wrap Around

# CASE PACKER MACHINE WRAP-AROUND



# Innovation and reliability for your packaging



Standing Mosaic System

The **Wrap Around Case Packer** by MF Tecno is the ideal solution for the automation of packaging in wrap around cartons. This automatic machine creates **the package directly around the product**, starting from an open die-cut carton that is then sealed with hot melt glue, offering a versatile and customizable solution.

Designed to ensure maximum precision and speed, this machine is able to handle a wide range of products and formats, ensuring resistant packaging optimised for transport.

Laying flat Mosaic System





Advanced technology  
to create perfect packaging



Thanks to an intelligent handling system and advanced electronic control, the Wrap Around Case Packer ensures the carton is formed, filled and closed with maximum efficiency.

The fully automated process reduces material waste and optimizes production times, making it ideal for companies looking to increase productivity without sacrificing quality.

# An Investment for the Future

Choosing the **Wrap Around Case Packer** by MF Tecno means investing in a cutting-edge technological solution, capable of optimizing the entire packing process and improving the company's competitiveness.



## Speed

The machine is **up to 20 boxes/min**, ensuring a significant increase in production efficiency.

## Flexibility

The machine is designed to handle a wide range of packages, with quick and intuitive adjustments.

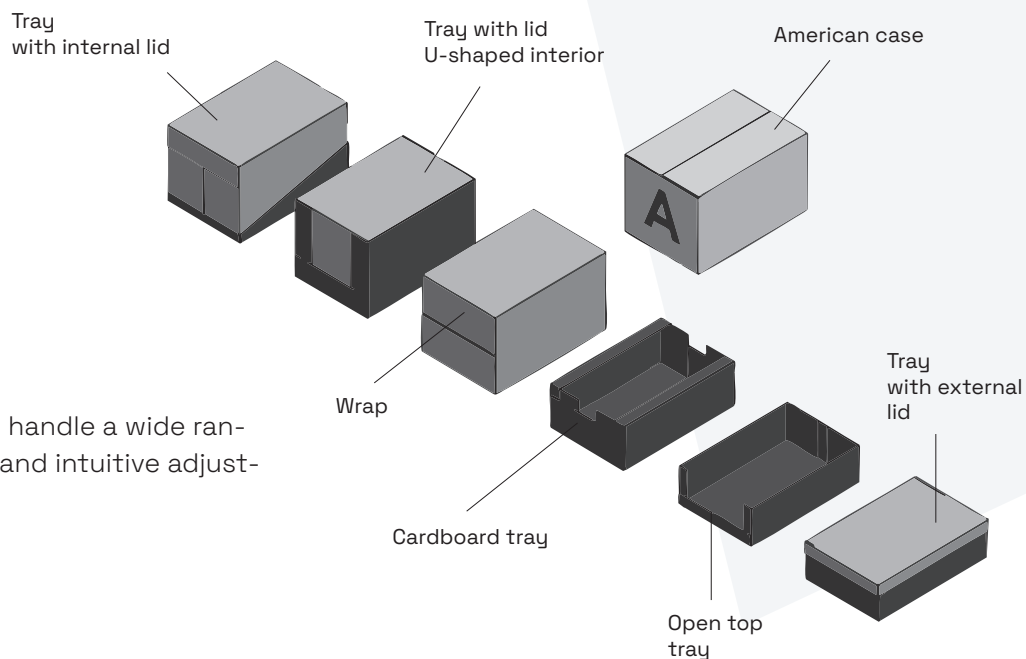

# Easy Maintenance and Accessibility

The **MF Tecno Wrap Around Case Packer** is designed to be intuitive to use, with a user-friendly touch screen interface that allows precise control of operations. The simplified maintenance system ensures reduced machine downtime, increasing overall productivity.



## Ergonomic

Designed to reduce operator effort, thanks to an intuitive interface and easy access to key components.

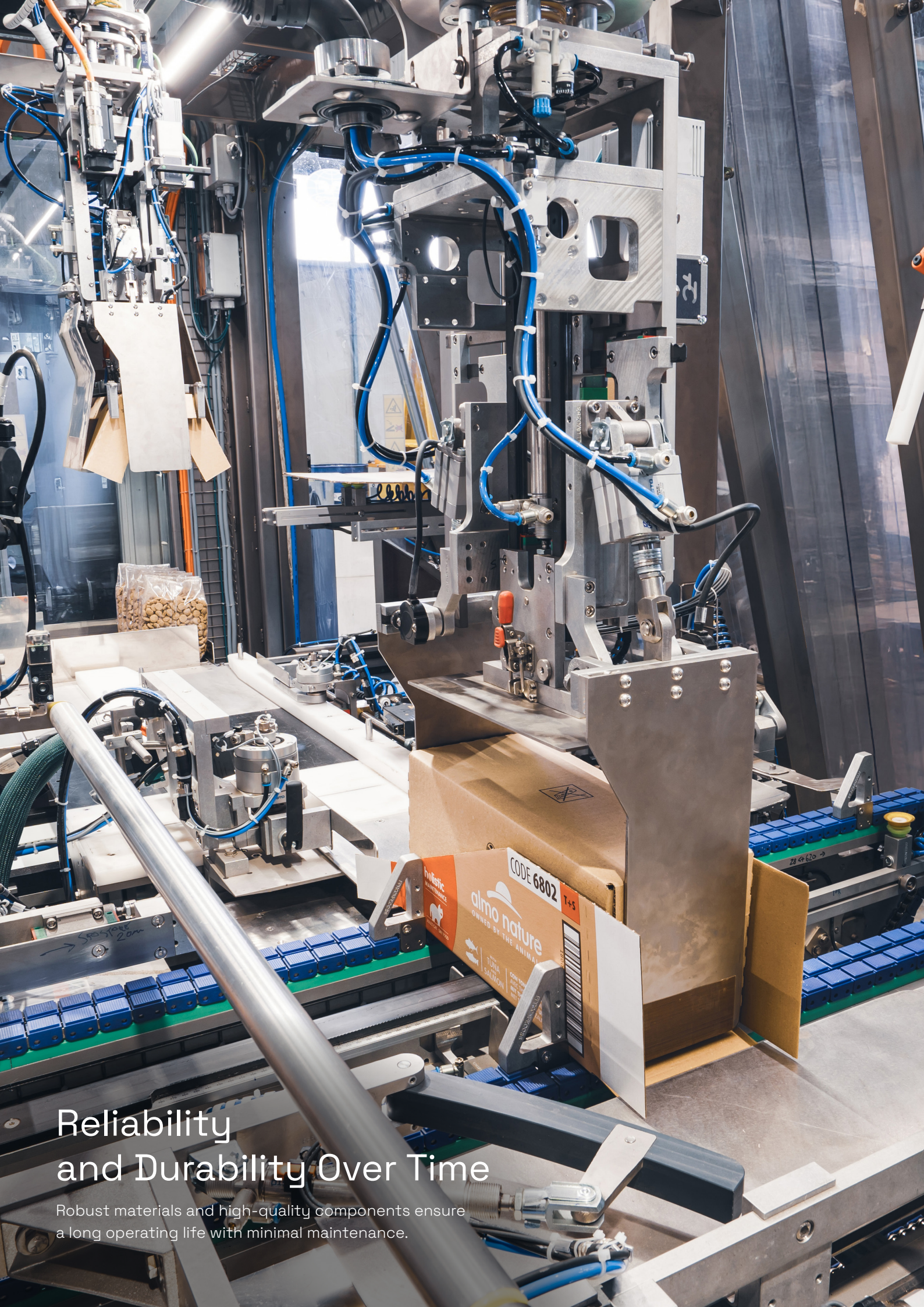

## Reliability and Durability Over Time

Robust materials and high-quality components ensure a long operating life with minimal maintenance.



# Versatility and Adaptability to Different Sectors

## FEED

- Sacks
- Carton boxes
- Bags (Pillows, Doypack, Flat Bottom, Gusseted)
- Cans



## CHEMISTRY AND PHARMACEUTICAL

- Products in bottles
- Rigid containers



## PET FOOD

Tailor-made packaging solutions for the pet food industry



## Main Features

- 1. Accuracy and Speed:** The advanced structure allows for consistent high-speed production with accurate control of each stage of the process.
- 2. Adaptability to Different Formats:** The machine is designed to handle a wide range of packages, with quick and intuitive adjustments.
- 3. Reliability and Durability:** Robust materials and high-quality components ensure a long operating life with minimal maintenance.
- 4. Integration with Production Lines:** It can be easily integrated with other upstream and downstream automation systems.
- 5. Ease of Maintenance:** Quick access to the main components, facilitating cleaning and routine maintenance operations, reducing machine downtime and optimising productivity.
- 6. Product Respect:** The Wrap Around MF Tecno is designed to ensure maximum respect for the product during all the phases.

# MASSINI

INDUSTRIES

MIAL ADVANCED INDUSTRIAL TECHNOLOGIES **mf** PACKAGING SYSTEMS  
TECNO

[www.massiniindustries.com](http://www.massiniindustries.com)

Massini Industries srl  
Via Porziuncola, 28  
06081 Tordandrea di Assisi (PG) - Italy  
+39 075 8042312 - [info@mftecno.com](mailto:info@mftecno.com)  
[www.mftecno.com](http://www.mftecno.com)